

PPTC-Polymer PTC Resettable Fuse: KRG Series



6Vdc/16Vdc Radial Ledged Type

■ Features

1. RoHS & Halogen-Free (HF) compliant
2. Radial leaded devices
3. Broadest range of resettable devices available in the industry
4. Hold current ratings from 0.75 to 15A
5. Maximum voltage: 6Vdc / 16Vdc
6. Operating & storage temperature range: -40 ~ +85°C
7. Agency Recognition : UL / cUL / TUV

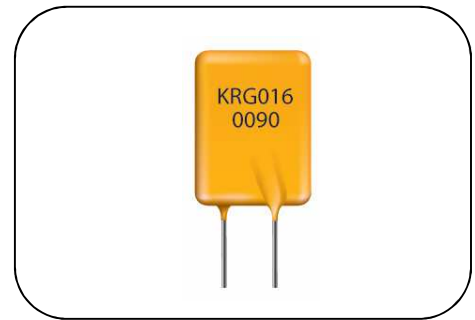

■ Recommended Applications

1. Motors / fans
2. Keyboard / mouse
3. Transformers
4. Industrial controls

■ Part Number Code

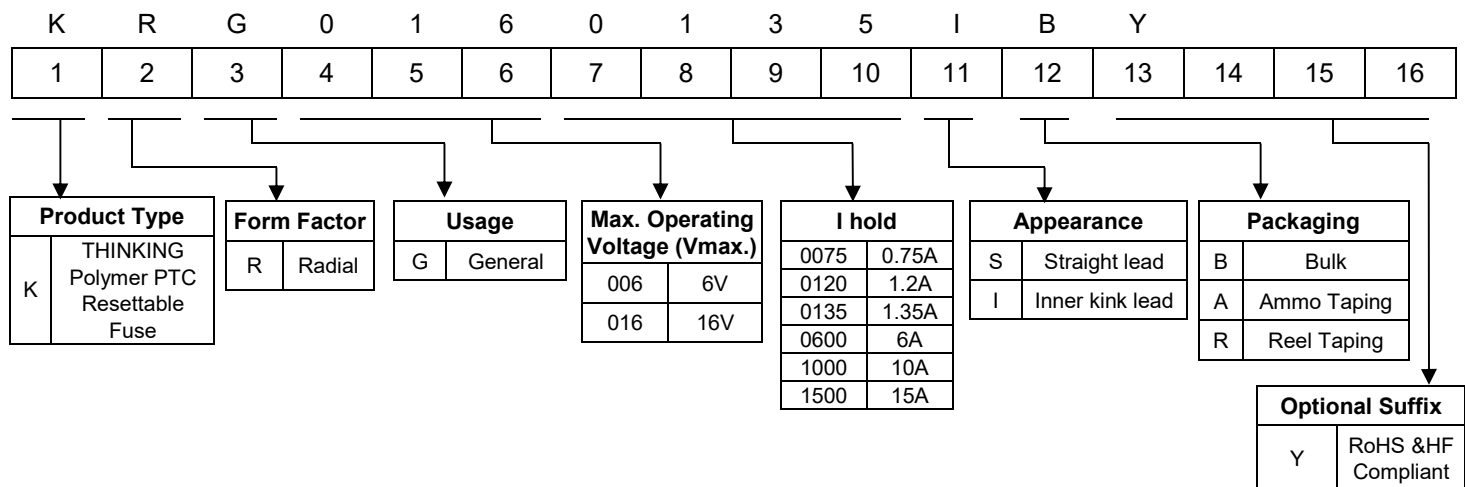

■ Structure and Dimensions

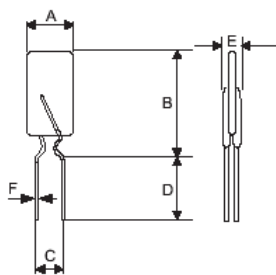

Style 1
(Inner Kink)

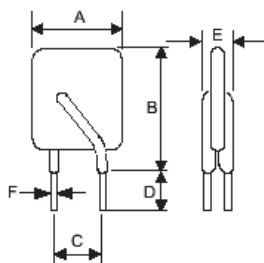

Style 2
(Straight Lead)

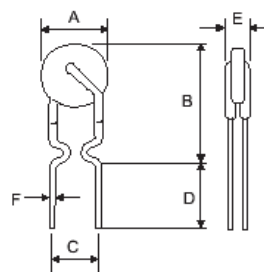

Style 3
(Inner Kink)

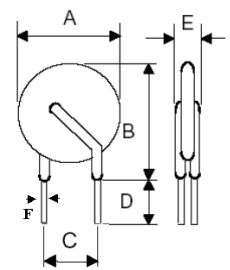

Style 4
(Straight Lead)

Marking: Device is marked with product type, Vmax, and I hold.

PPTC-Polymer PTC Resettable Fuse: KRG Series



6Vdc/16Vdc Radial Leaded Type

(Unit: mm)

Part No.	A		B				C		D		E		F		Figure
	Min.	Max.	Straight Lead		Inner Kink		Min.	Max.	Min.	Max.	Min.	Max.	Min.	Max.	Style
			Min.	Max.	Min.	Max.									
KRG0060075	4.4	7.0	--	--	4.4	11.4	4.2	5.8	7.6	11.6	1.2	3.1	0.48	0.52	3,4
KRG0060120	4.8	7.0	--	--	4.8	11.7	4.2	5.8	7.6	11.6	1.2	3.1	0.48	0.52	3,4
KRG0060155	6.0	6.9	--	--	6.0	11.7	4.2	5.8	7.6	11.6	1.2	3.1	0.48	0.52	3,4
KRG0160090	5.1	7.4	6.6	12.2	6.6	12.2	4.2	5.8	7.6	11.6	1.2	3.1	0.48	0.52	1,2
KRG0160110	5.1	7.4	8.6	14.2	8.6	14.2	4.2	5.8	7.6	11.6	1.2	3.1	0.48	0.52	1,2
KRG0160135	7.6	8.9	7.6	13.5	7.6	13.5	4.2	5.8	7.6	11.6	1.2	3.1	0.48	0.52	1,2
KRG0160160	7.6	8.9	9.3	15.2	9.3	15.2	4.2	5.8	7.6	11.6	1.2	3.1	0.48	0.52	1,2
KRG0160185	8.6	10.2	10.2	15.7	10.2	15.7	4.2	5.8	7.6	11.6	1.2	3.1	0.48	0.52	1,2
KRG0160250	10.2	11.4	12.4	18.3	12.4	20.5	4.2	5.8	7.6	11.6	1.2	3.1	0.48	0.52	1,2
KRG0160300	5.9	7.1	5.9	11.0	5.9	14.0	4.2	5.8	7.6	11.6	2.0	3.5	0.78	0.82	1,2
KRG0160400	7.7	8.9	7.7	12.8	7.7	14.8	4.2	5.8	7.6	11.6	2.0	3.5	0.78	0.82	1,2
KRG0160500	9.2	10.4	9.2	14.3	9.2	16.0	4.2	5.8	7.6	11.6	2.0	3.5	0.78	0.82	1,2
KRG0160600	9.5	10.7	12.0	17.1	12.0	19.0	4.2	5.8	7.6	11.6	2.0	3.5	0.78	0.82	1,2
KRG0160700	10.0	11.2	14.5	19.7	14.5	22.0	4.2	5.8	7.6	11.6	2.0	3.5	0.78	0.82	1,2
KRG0160800	11.5	12.7	15.8	20.9	15.8	23.0	4.2	5.8	7.6	11.6	2.0	3.5	0.78	0.82	1,2
KRG0160900	12.8	14.0	16.5	21.9	16.5	24.0	4.2	5.8	7.6	11.6	2.0	3.5	0.78	0.82	1,2
KRG0161000	15.3	16.5	21.0	25.2	21.0	28.0	4.2	5.8	7.6	11.6	2.0	3.5	0.78	0.82	1,2
KRG0161100	16.3	17.5	21.0	26.0	21.0	29.0	4.2	5.8	7.6	11.6	2.0	3.5	0.78	0.82	1,2
KRG0161200	16.3	17.5	22.4	28.0	22.4	31.0	9.2	10.8	7.6	11.6	2.0	3.5	0.98	1.02	1,2
KRG0161300	20.5	21.6	23.6	29.2	23.6	32.0	9.2	10.8	7.6	11.6	2.0	3.5	0.98	1.02	1,2
KRG0161400	22.4	23.5	22.4	27.9	22.4	30.0	9.2	10.8	7.6	11.6	2.0	3.5	0.98	1.02	1,2
KRG0161500	23.5	25.1	23.5	29.0	23.5	32.0	9.2	10.8	7.6	11.6	2.0	3.5	0.98	1.02	1,2

Electrical Characteristics at 23°C

Part No.	Vmax.	I _{max} .	I _{hold}	I _{trip}	P _d (Typ.)	Maximum Time to Trip		Resistance		Safety Approvals	
	(V _{dc})	(A)	(A)	(A)	(W)	Current	Time	Initial Ri	Post Trip R1	UL/cUL	TUV
						(A)	(Sec)	Min. (Ω)	Max(Ω)		
KRG0060075	6	40	0.75	1.50	0.30	8.00	0.40	0.110	0.230	√	√
KRG0060120	6	40	1.20	2.40	0.60	8.00	0.50	0.065	0.140	√	√
KRG0060155	6	40	1.55	3.10	0.70	7.80	2.20	0.043	0.100	√	√
KRG0160090	16	40	0.90	1.80	0.60	8.00	1.20	0.070	0.180	√	√
KRG0160110	16	40	1.10	2.20	0.70	8.00	2.30	0.050	0.140	√	√
KRG0160135	16	40	1.35	2.70	0.80	8.00	4.50	0.040	0.120	√	√
KRG0160160	16	40	1.60	3.20	0.90	8.00	9.00	0.030	0.110	√	√
KRG0160185	16	40	1.85	3.70	1.00	8.00	10.00	0.030	0.090	√	√
KRG0160250	16	40	2.50	5.00	1.20	8.00	40.00	0.020	0.070	√	√
KRG0160300	16	100	3.00	5.10	2.30	15.00	1.00	0.038	0.098	√	√
KRG0160400	16	100	4.00	6.80	2.40	20.00	1.70	0.021	0.060	√	√
KRG0160500	16	100	5.00	8.50	2.60	25.00	2.00	0.010	0.034	√	√
KRG0160600	16	100	6.00	10.20	2.80	30.00	3.30	0.006	0.028	√	√
KRG0160700	16	100	7.00	11.90	3.00	35.00	3.50	0.006	0.020	√	√
KRG0160800	16	100	8.00	13.60	3.00	40.00	5.00	0.005	0.018	√	√
KRG0160900	16	100	9.00	15.30	3.30	45.00	5.50	0.005	0.014	√	√
KRG0161000	16	100	10.00	17.00	3.60	50.00	6.00	0.004	0.010	√	√
KRG0161100	16	100	11.00	18.70	3.70	55.00	7.00	0.003	0.009	√	√
KRG0161200	16	100	12.00	20.40	4.20	60.00	7.50	0.003	0.009	√	√
KRG0161300	16	100	13.00	22.10	4.60	65.00	8.50	0.002	0.008	√	√
KRG0161400	16	100	14.00	23.80	4.60	70.00	9.00	0.002	0.007	√	√
KRG0161500	16	100	15.00	25.50	4.60	75.00	10.00	0.002	0.007	√	√

Note: UL&cUL File No: E138827

TUV File No: J 50161442, J 50231157



Typical Time to Trip Curves at 23°C

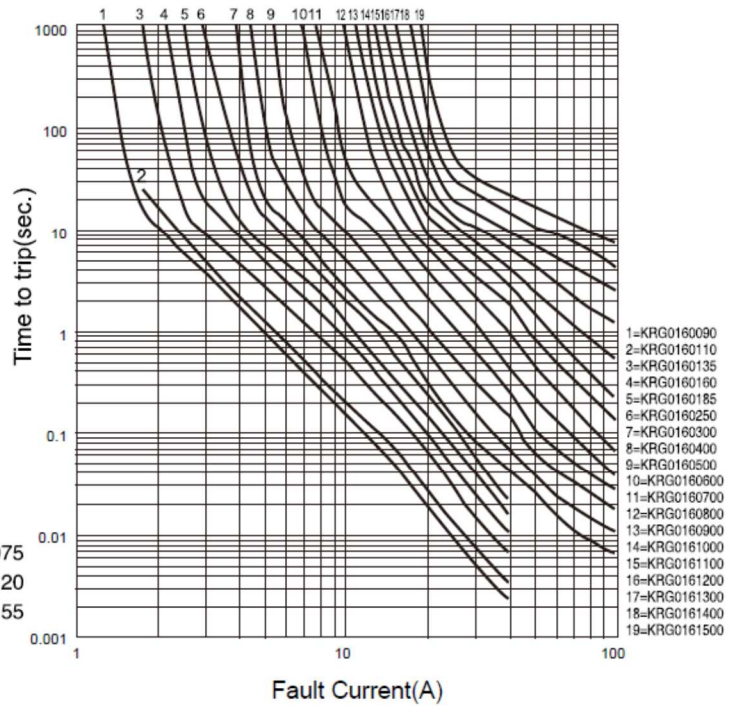
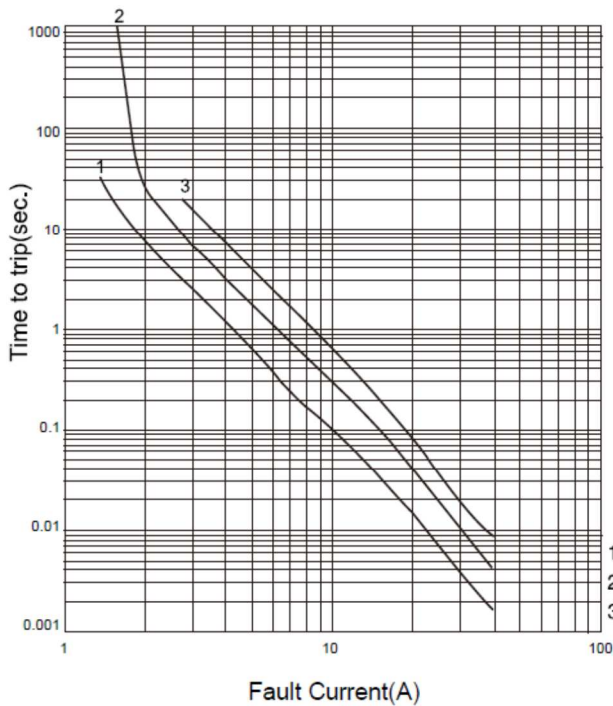

Ihold & Itrip Thermal Derating Curve

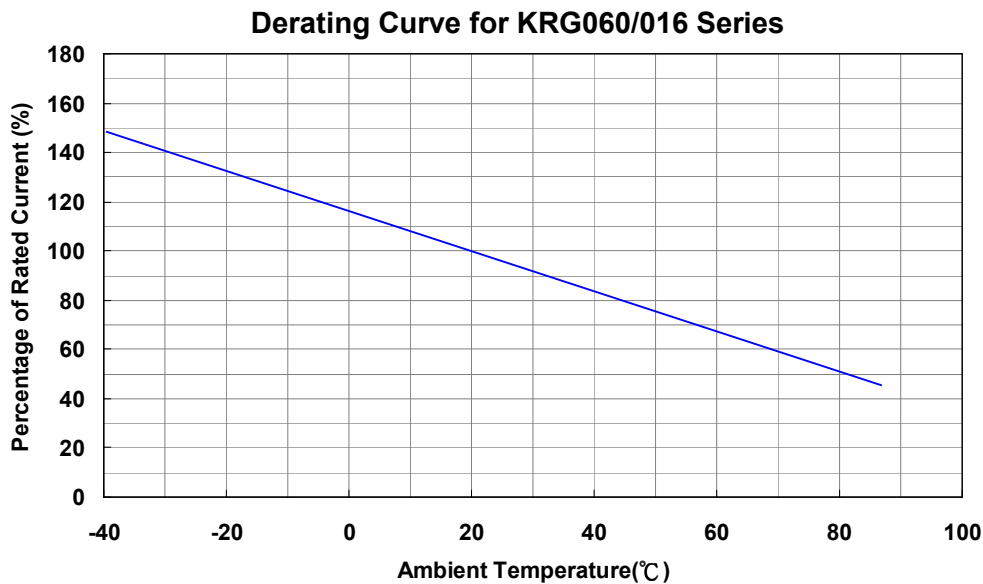

PPTC-Polymer PTC Resettable Fuse: KRG Series



6Vdc/16Vdc Radial Leded Type

Hold Thermal Derating Chart

(Unit: A)

Part No.	Ambient Temperature								
	-40℃	-20℃	0℃	23℃	40℃	50℃	60℃	70℃	85℃
KRG0060075	1.05	0.95	0.85	0.75	0.64	0.58	0.51	0.44	0.35
KRG0060120	1.69	1.52	1.36	1.20	1.02	0.92	0.82	0.71	0.56
KRG0060155	2.17	1.96	1.75	1.55	1.32	1.19	1.05	0.91	0.73
KRG0160090	1.33	1.20	1.05	0.90	0.77	0.69	0.61	0.53	0.42
KRG0160110	1.63	1.46	1.29	1.10	0.94	0.85	0.75	0.65	0.52
KRG0160135	2.00	1.80	1.58	1.35	1.15	1.04	0.92	0.80	0.63
KRG0160160	2.37	2.13	1.87	1.60	1.36	1.23	1.09	0.94	0.75
KRG0160185	2.74	2.46	2.16	1.85	1.57	1.42	1.26	1.09	0.87
KRG0160250	3.63	3.25	2.88	2.50	2.08	1.93	1.70	1.48	1.18
KRG0160300	4.40	3.96	3.60	3.00	2.55	2.31	2.10	1.77	1.35
KRG0160400	5.90	5.28	4.80	4.00	3.40	3.08	2.80	2.36	1.80
KRG0160500	7.30	6.60	6.00	5.00	4.25	3.85	3.60	2.95	2.25
KRG0160600	8.80	7.92	7.20	6.00	5.10	4.62	4.20	3.54	2.70
KRG0160700	10.30	9.24	8.40	7.00	5.95	5.39	5.00	4.13	3.15
KRG0160800	11.70	10.56	9.60	8.00	6.80	6.16	5.60	4.72	3.60
KRG0160900	13.20	11.88	10.70	9.00	7.65	6.93	6.40	5.31	4.05
KRG0161000	14.70	13.20	12.00	10.00	8.50	7.70	7.00	5.90	4.50
KRG0161100	16.10	14.52	13.10	11.00	9.35	8.47	7.80	6.49	4.95
KRG0161200	17.60	15.84	14.40	12.00	10.20	9.24	8.40	7.08	5.40
KRG0161300	17.70	16.30	14.80	13.00	11.05	10.01	9.60	7.67	5.85
KRG0161400	20.50	18.48	16.80	14.00	11.90	10.78	9.80	8.26	6.30
KRG0161500	20.40	18.80	17.10	15.00	12.75	11.55	11.10	8.85	6.75

Reliability

Item	Standard	Test Condition/methods	Criteria
Resistance to Soldering Heat	IEC 60068-2-58	260 ± 5 °C , 10 ± 1 sec	Rf<R1max No visible damage
Passive Aging	IEC 60738-1	85±5℃, 1000±24hrs	±5% typical resistance change
Humidity Aging	IEC 60068-2-78	85±5℃, 80~85%RH, 1000±5hrs	±5% typical resistance change
Rapid Change of Temperature	IEC 60738-1	85±5/-40±5℃, 10 cycles, Duration:30min	±5% typical resistance change
Overload Endurance	UL 1434	Vmax,120% Imax ,50 cycles Vmax,300% Itrip ,6000 cycles	No visible damage
Trip endurance	UL 1434	Vmax, Itrip ≤ I ≤ Imax , 1000±24hrs	No visible damage

PPTC-Polymer PTC Resettable Fuse: KRG Series



6Vdc/16Vdc Radial Leaded Type

■ Packaging

Devices are taped according to IEC 60286-2 standards. See table below and Fig. 1~4 for details.

Dimension description	IEC Mark	Dimension (mm)	Tolerance (mm)
Sprocket hole pitch	P ₀	12.70	±0.3
Ordinate to adjacent component lead KRG0060075, KRG0060120, KRG0060155 KRG0160090~KRG0161100	P ₁	3.85	±0.7
Ordinate to adjacent component lead KRG0161200~KRG0161500		7.70	±0.7
Device pitch KRG0060075, KRG0060120, KRG0060155 KRG0160090~KRG0160600	P	12.70	±1.0
Device pitch KRG0160700~KRG0161400		25.40	±1.0
Device pitch KRG0161500		38.10	±1.0
Lead spacing KRG0060075, KRG0060120, KRG0060155 KRG0160090~KRG0161100	F	5.00	±0.8
Lead spacing KRG0161200~KRG0161500		10.00	
Lead diameter KRG0060075, KRG0060120, KRG0060155 KRG0160090~KRG0160250	d	0.50	±0.02
Lead diameter KRG0160300~KRG0161500		0.80	
Carrier tape width	W	18.00	+1/-0.5
Top distance between tape edges	W ₂	3.00	Max
Hold-down tape width	W ₀	12.00	±1.5
Sprocket hole position	W ₁	9.00	+0.75/-0.5
Abscissa to top KRG0060075, KRG0060120, KRG0060155 KRG0160090~KRG0160600	H ₁	32.20	Max.
Abscissa to top KRG0160700~KRG0161500		47.50	
Abscissa to plane (straight lead)	H	18.00	+2/-0
Abscissa to plane (kinked lead)	H ₀	16.00	±0.5
Sprocket hole diameter	D ₀	4.00	±0.2
Lead protrusion	L ₁	0.50	Max.
Tape thickness	T	0.60	±0.2
Body lateral deviation	Δh	2.00	Max.
Body tape plane deviation	Δp	1.00	Max.
Reel width	W ₃	See reel specification	±1
Reel diameter		340.00	±10
Arbor hole diameter	n ₀	31.00	±1
Core diameter	n	80.00	Min.

6Vdc/16Vdc Radial Leded Type

- Taping Specification

Fig.1. For KRG0060075, KRG0060120 and KRG0060155

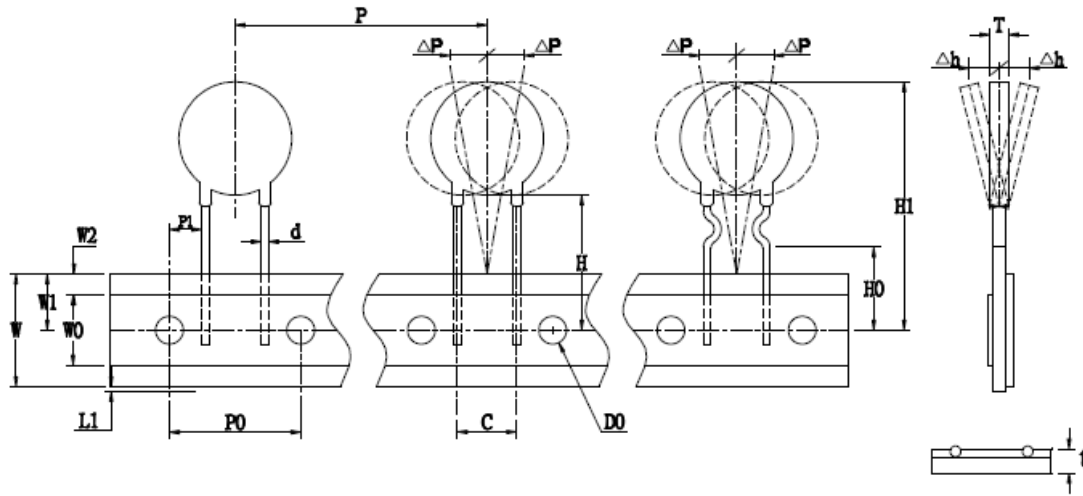

Fig.2. For KRG0160090 ~ KRG0161100

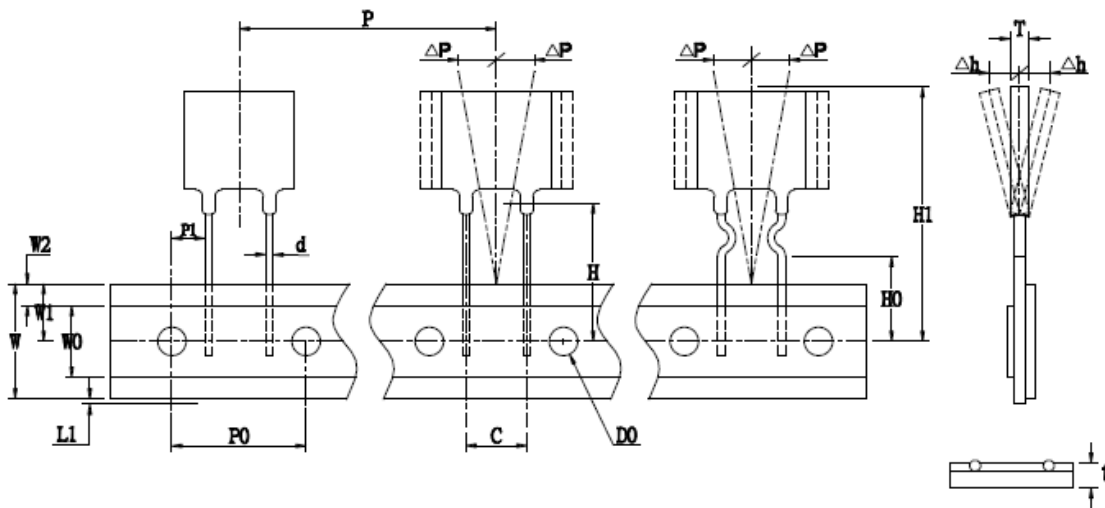
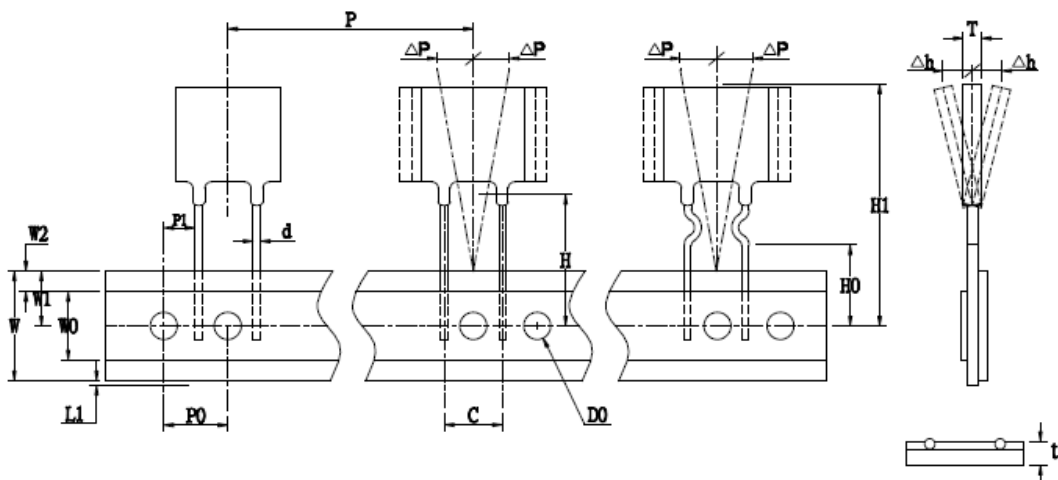
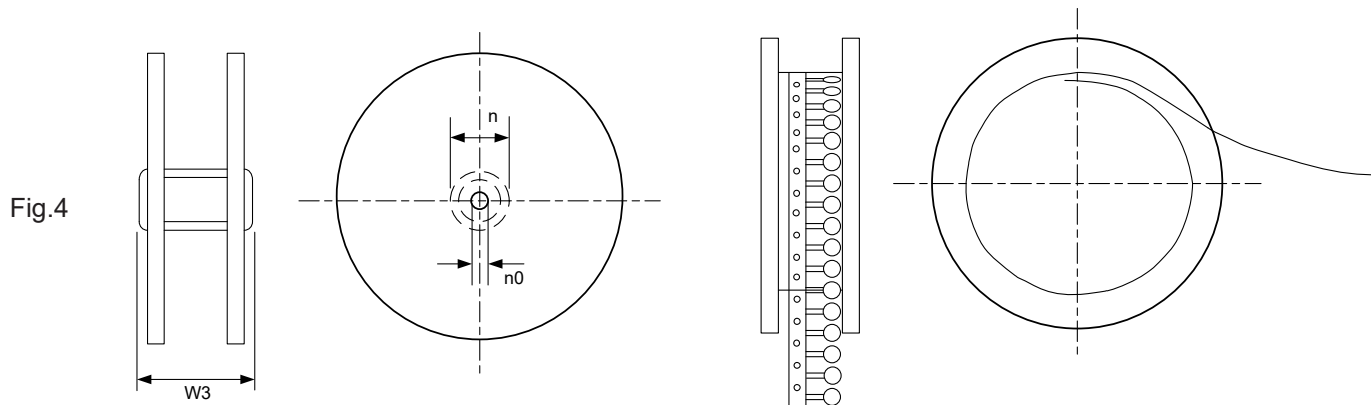

Fig.3. For KRG0161200 ~ KRG0161500



- Reel Specification



Series	W3 (mm)
KRG006 (0075~0155) KRG016 (0090~0700)	46±1
KRG016 (0900~1500)	55±1

- Quantity

- Bulk Packing

Series	Quantity (pcs/bag)
KRG0060075, KRG0060120, KRG0060155	1,000
KRG016 (0090~0160)	1,000
KRG016 (0185~0900)	500
KRG016 (1000~1500)	250

- Reel Packing

Series	Quantity (pcs/reel)
KRG0060075, KRG0060120, KRG0060155	3,000
KRG016 (0090~0185)	3,000
KRG016 (0250~0400)	2,500
KRG016 (0500~0700)	1,500
KRG016 (0800~1500)	1,000

- **Ammo Packing**

Series	Quantity (pcs/box)
KRG0060075, KRG0060120, KRG0060155	1,000
KRG016 (0090~0600)	1,000
KRG016 (0700~1500)	500

(Unit: mm)

Series	W	L	H
KRG0060075, KRG0060120, KRG0060155	345	275	55
KRG0160090~KRG0161500	345	275	55

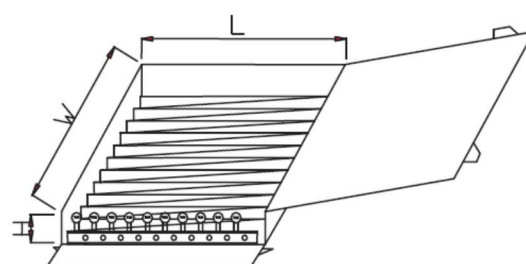

- **Warehouse Storage Conditions of Products**

- Storage Conditions:

1. Storage Temperature: -10°C~+40°C
2. Relative Humidity: ≤75%RH
3. Keep away from corrosive atmosphere and sunlight.

- Period of Storage: 1 year